



**iVario®**

The Game Changer.

Production food service.



iVario live

# Countless tasks. One iVario.

Looks like a tilting skillet, but it does so much more. The iVario boils, pan-fries, deep-fries, and pressure-cooks, which means it replaces tilting skillets, kettles, deep-fat fryers, and pressure cookers. Even better, it works up to four times faster\* than conventional kitchen equipment, using up to 40% less energy\*. In other words, it does more in less time to ensure efficient production.

## Replaces



tilting skillets



kettles



deep fryers



pressure cookers



\* Compared to conventional tilt skillets, kettles, and deep-fat fryers.  
For more information, visit [rational-online.com](http://rational-online.com).

# How you benefit.

## Standardized food quality.

Delicious. On any scale.

The art of production food service: producing mass quantities with efficiency. Over and over again. The art of the iVario: meeting every expectation perfectly. By implementing specifications precisely. By handling products optimally. Reacts to even the slightest changes promptly. Nothing burns, nothing boils over.

## More output.

Endless production.

Dinner for 300? For 3,000? More? Par for the course in production food service – and the iVario. It has the speed, the reserve power, and the capacity to produce large quantities of food efficiently. Exceptional uniformity, minimal energy consumption, and delicious roasted flavors: all in perfect balance.

## Save time, space, and ingredients.

The iVario does it all.

Doing things right the first time saves a lot of time and effort. It's also the iVario's specialty. It's numerous cooking processes can replace conventional commercial kitchen appliances, which saves a lot of space. Because its speed saves a lot of time. Because its consistent, high-quality output saves a lot of ingredients. In other words, it does everything right.

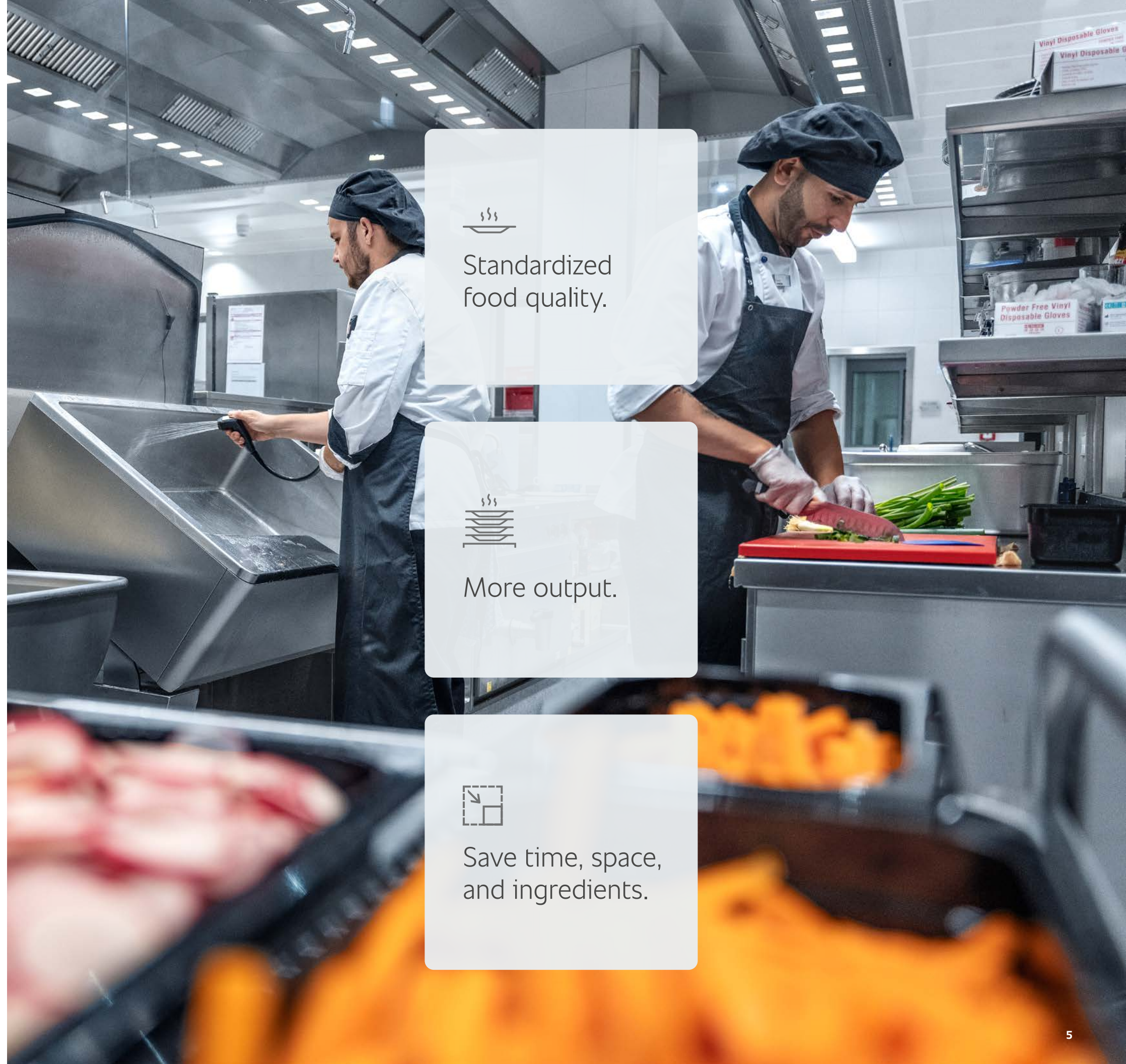

Standardized food quality.



More output.



Save time, space, and ingredients.

## Impressive performance. Top-quality results.

Food handled with ease, many different foods – all from the iVario. Quick and consistent. In quantities of any size.

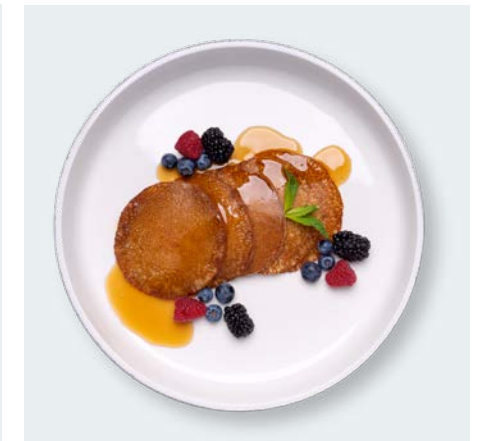
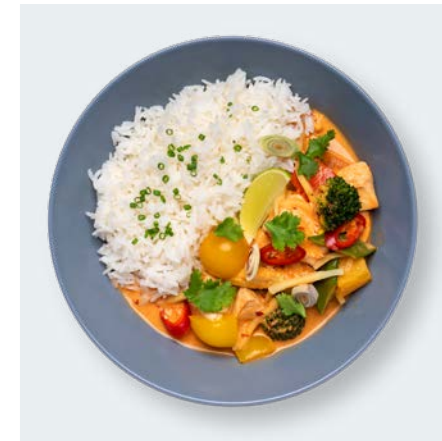
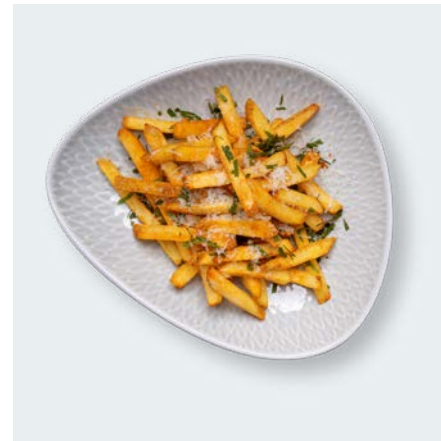
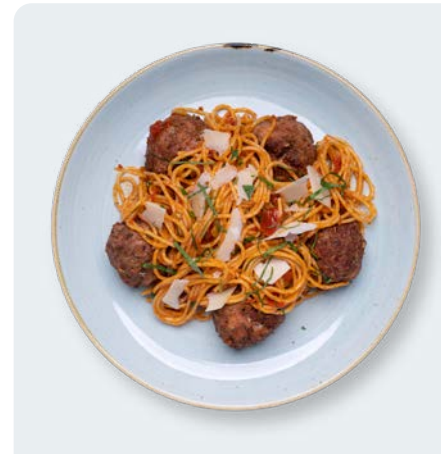

### For example\*:

- › **Blanching:** 40 lb of broccoli in 23 minutes
- › **Braising:** 1,200 servings of bolognese sauce in 90 minutes
- › **Boil:** 400 servings of vegetable soup in 35 minutes
- › **Deep-fry:** 26 lb of french fries in 19 minutes
- › **Boil:** 33 lb of pasta (in basket) in 22 minutes
- › **Pressure cooking:** 154 lb of braised meat in 120 minutes
- › **Boiling dairy:** 800 servings of rice pudding in 70 minutes
- › **Pan-fry:** 100 servings of fried rice in 20 minutes



\* iVario Pro XL, includes pre-heating, filling oil for frying and water for boiling.

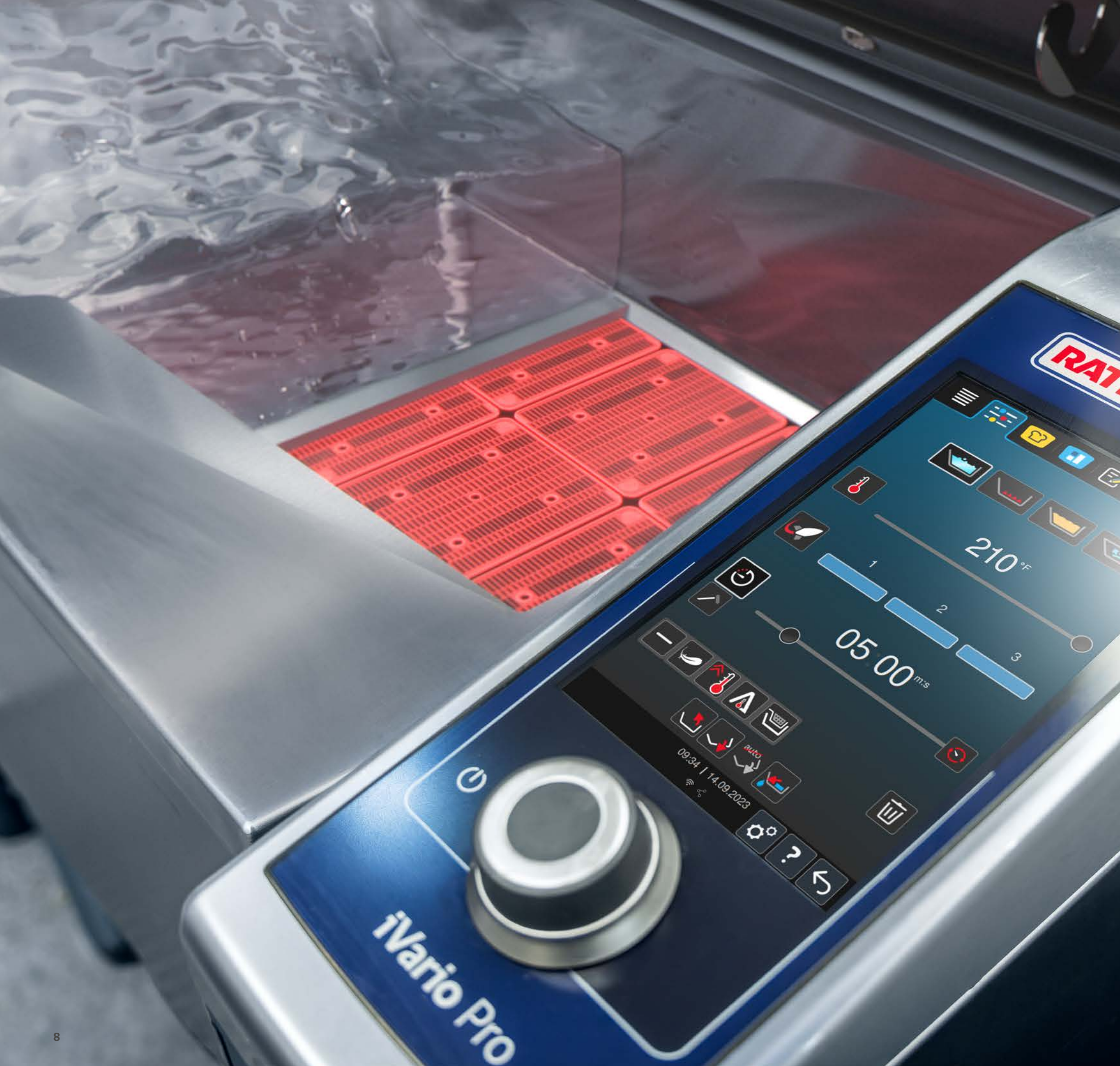

## Speed and precision. Managed performance.

Perfect. Intelligent. Powerful.  
Managed performance in the iVario:

- › A winning combination of ceramic heating elements and a highly responsive, scratch-resistant stainless steel pan base
- › Uniform heat distribution across the entire surface
- › Exceptional speed and efficiency
- › Consumes up to 40% less electricity than conventional appliances
- › Reserve power for large quantities
- › From room temperature to 392°F in 2.5 minutes
- › Boil 23.8 gallons of water in 13 minutes

Benefits:



iVarioBoost 

## Monitoring and support. The brain behind the iVario.

Continuously monitors and supports food production. At the touch of a button.

- › Easy to operate – almost no instruction required
- › Automatically adjusts cooking processes to fit each dish, including basket auto-lift
- › Delivers your target results every time
- › Only calls you over when you need to do something
- › Networking via ConnectedCooking
- › Practical search assistant

### It even works nights.

To cook overnight, just load the iVario, start the cooking process, and then unload the finished food the next morning.

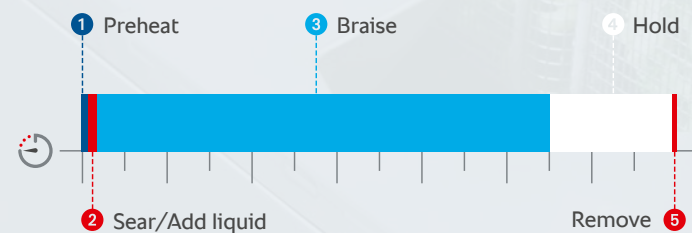

Benefits:



iCookingSuite 



## Monitoring and support.

Your intelligent assistant in everyday kitchen work.

An operating concept that sets new standards: Intuitive display with pre-installed cooking procedures. Touch screen and rotary dial controls allow quick, easy and efficient operation.

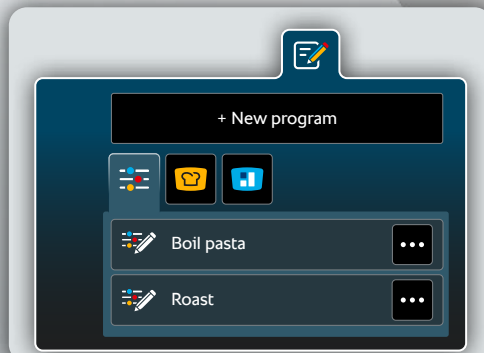
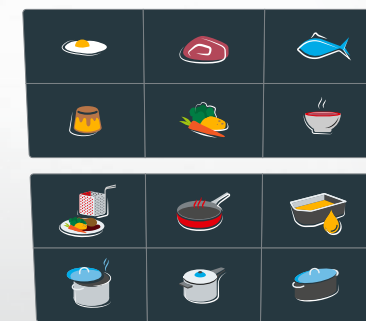

Preset, user-specific, manual – programming functions let users tailor cooking processes to individual workflows.

Use MyDisplay to adjust the user interface so that only the functions currently needed will be visible.

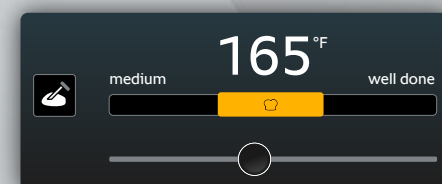
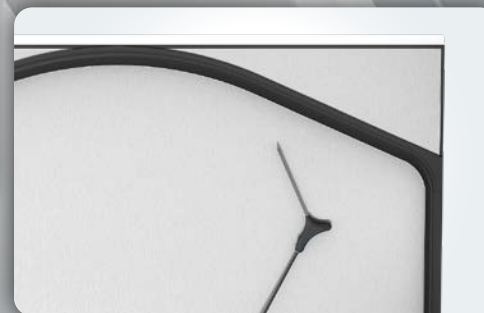

The integrated core temperature probe uses six measurement points to detect product sizes and quantities. The food reaches the specified core temperature avoiding overcooking and producing the expected results.

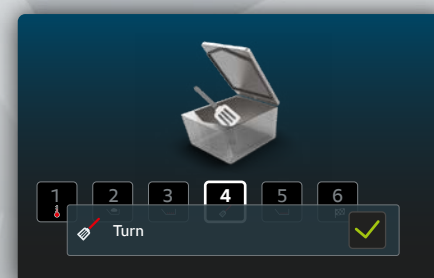

Intelligent control and interactive communication with the iVario's cooking intelligence. It adjusts cooking processes individually to each dish, adapts to users' habits, and notifies them when something needs to be done.

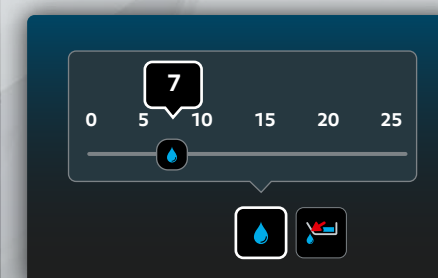

Automatic water filling. At the touch of a button, measured precisely. With an integrated drain. That's true flexibility.



Continue cooking. Boil down. Hold. Start a new load. Choose the options you need, whenever you need them. Even in the middle of cooking. Appliance operation: easier than ever. Food quality: assured.



ConnectedCooking digital kitchen management lets you create and distribute cooking programs, configure screen layout via MyDisplay, update unit software, and capture HACCP data. No matter where the cooking systems are.



**Pressure cooking.**

Builds up pressure to take the pressure off.

The optional intelligent pressure-cooking function kicks things into even higher gear\*:

- > Soups, stews, casseroles, braised dishes, and legumes cook up to 46% faster
- > Easy and safe to use
- > No loss of quality
- > Faster pressure build-up and release
- > No additional maintenance required

**Shorter cooking times**

Example: 150 lb chickpeas (soaked 24 hours) in the iVario Pro XL.

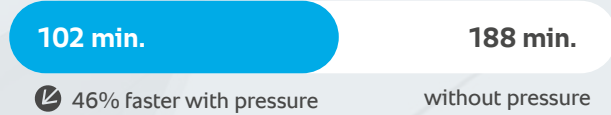

	Cooking	Pressure cooking	
Vegetable soup	72 min.	48 min.	⚡ 33%
Dry beans (not soaked)	65 min.	42 min.	⚡ 35%
Potatoes	43 min.	34 min.	⚡ 21%

**Benefit:**



\* Optional on iVario Pro 2-S, L, and XL

## Multifaceted and flexible.

# One unit, many options.

Use iZoneControl to turn a single iVario into up to four. For a more diverse and energy-efficient kitchen.

- › Divide the pan base into up to four temperature zones
- › Flexibility in zone size, position, and shape
- › Prepare different dishes in a single pan
- › Simultaneous or time-delayed, at the same or different temperatures
- › Heat only the area needed



Benefits:



iZoneControl 



1



2



3



4

- 1 iVario with base and feet
- 2 Curb installation
- 3 iVario with casters (available as an option)
- 4 iVario integrated into kitchen block

IP X5



## Setup options.

# Always the right size.

Whether it's enhancing a new kitchen or an existing one, the iVario adapts to any surroundings.

- > Can be installed atop work surfaces or tables, against walls, or integrated into kitchen suites
- > No front floor trough required thanks to an integrated water drain (rear floor sink required)
- > No slippery floors – greater work safety

## Streamlined kitchens.

With space and time.

Fewer appliances, more space to work. Do a lot in less time. Only the iVario offers that combination.

- › Replaces tilting pans, kettles, deep-fat fryers, and pressure cookers
- › Saves up to 33% more space
- › More efficient than conventional kitchen technology
- › No compromising on food quality

Benefit:



Benefit:



### Space savings\*

Kitchen setup Before

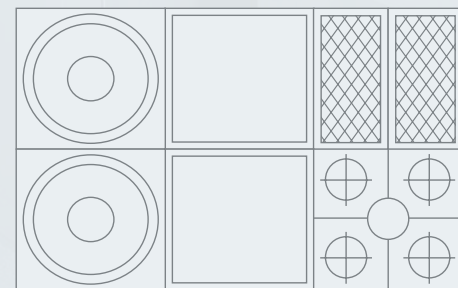

1 × stove  
2 × kettle  
2 × tilt skillet  
1 × deep-fryer

Kitchen setup After

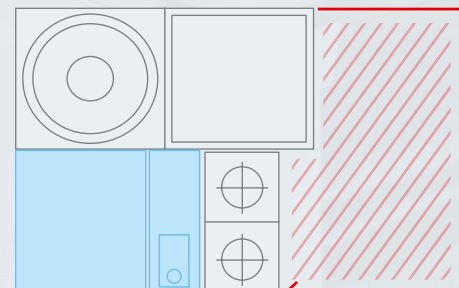

1 × stove  
1 × kettle  
1 × tilt skillet  
1 × iVario Pro L

**33 %**  
space savings

### Time savings\*

Boil Pasta

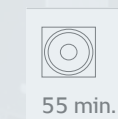

Pan-fry/Braise Chicken Alfredo

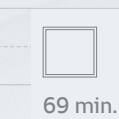

Deep-fry Fries

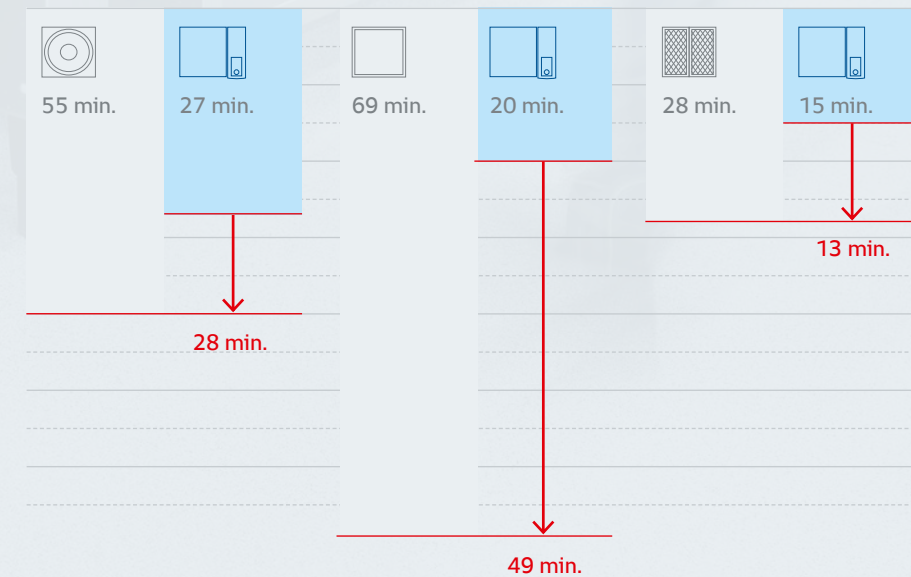
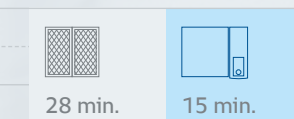

\* Includes pre-heating

# Modern work. Easier than ever.

The iVario makes kitchens ergonomic,  
labor-saving and efficient.

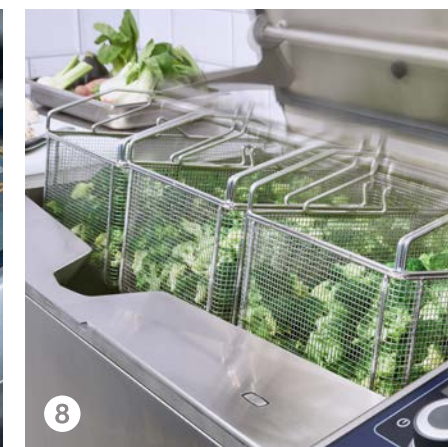
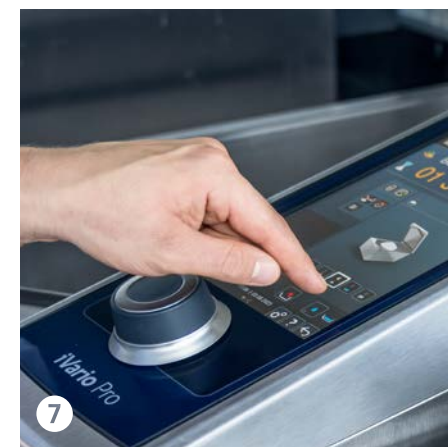
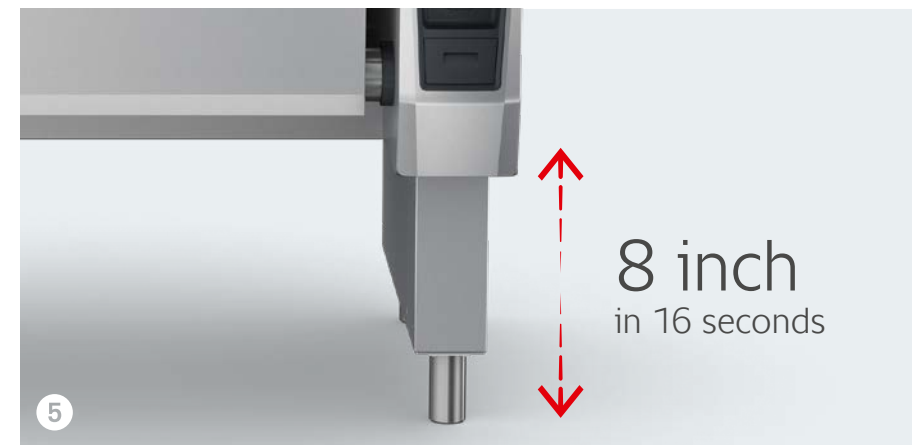
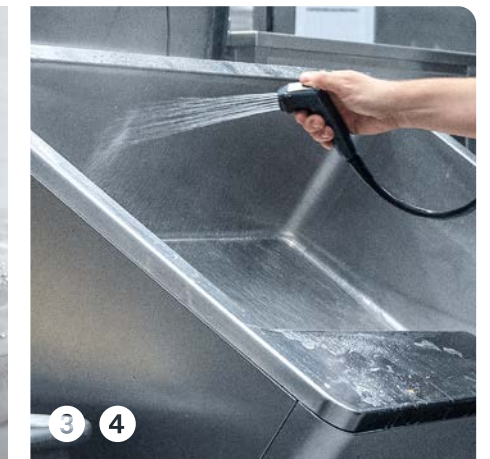
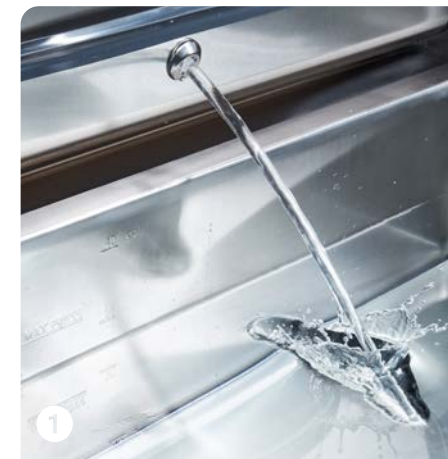
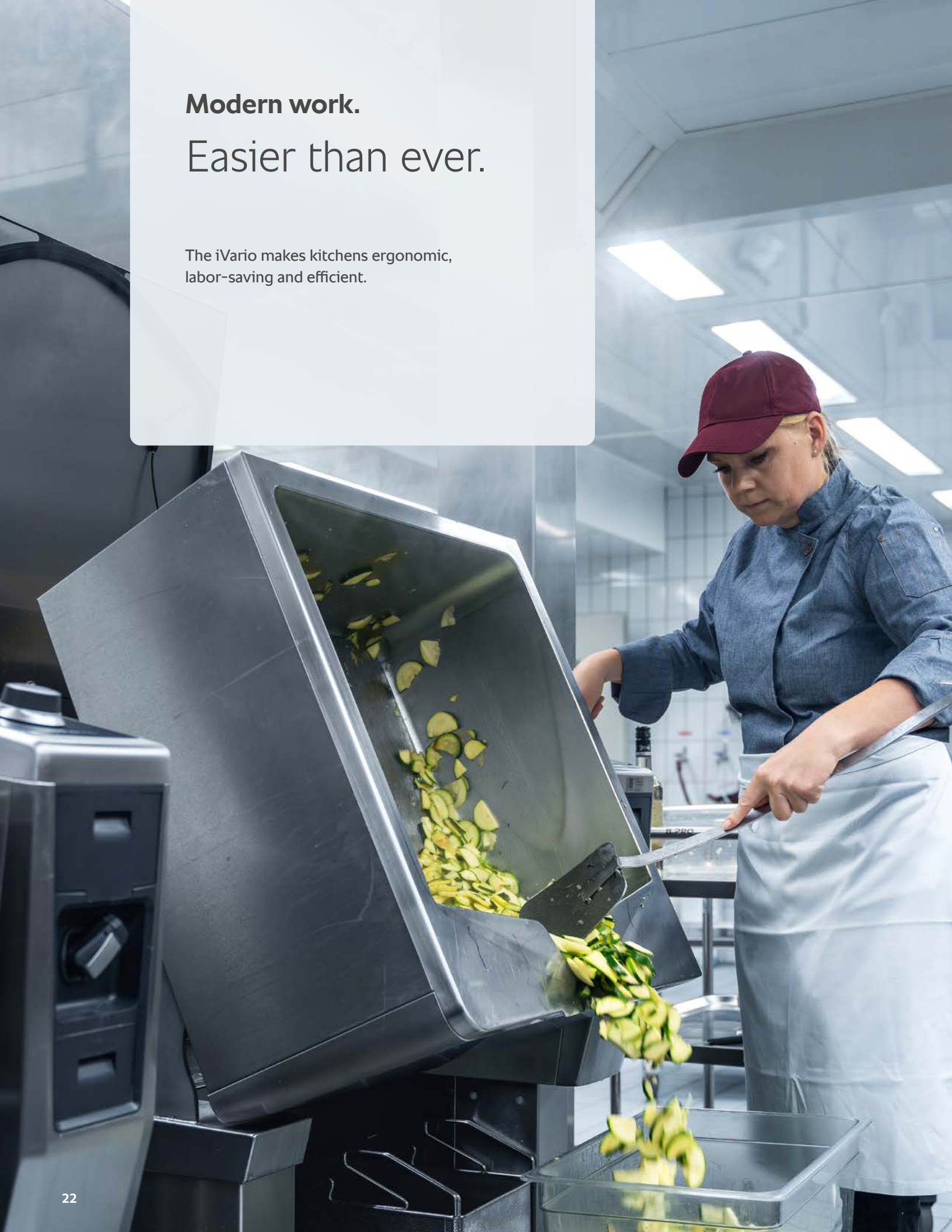

- 1 Automatic water inlet
- 2 Integrated water drain
- 3 Quick and easy cleaning
- 4 Cool pan edges and rounded corners
- 5 Height adjustment (option)
- 6 Easy, safe emptying
- 7 Clear, intuitive touch screen controls
- 8 AutoLift (automatic lifting and lowering function)
- 9 WiFi for networking
- 10 Integrated hand shower



## Accessories.

# Easier than ever.

Production food service operations need durable tools that make their work easier and deliver ideal results. They need RATIONAL accessories.



1



2



3



4

5

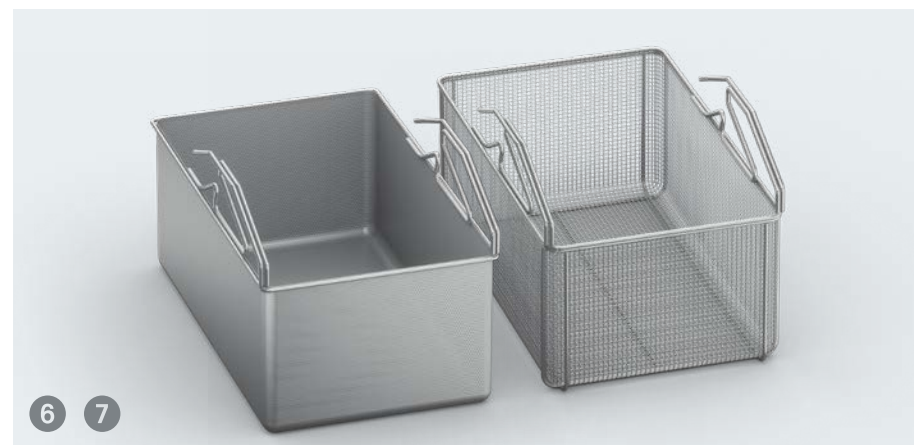

6

7



8

- 1 VarioMobil
- 2 Cleaning scrub
- 3 Strainer
- 4 Solid scoop
- 5 Perforated scoop
- 6 Boiling basket
- 7 Frying basket
- 8 Long spatula



More information

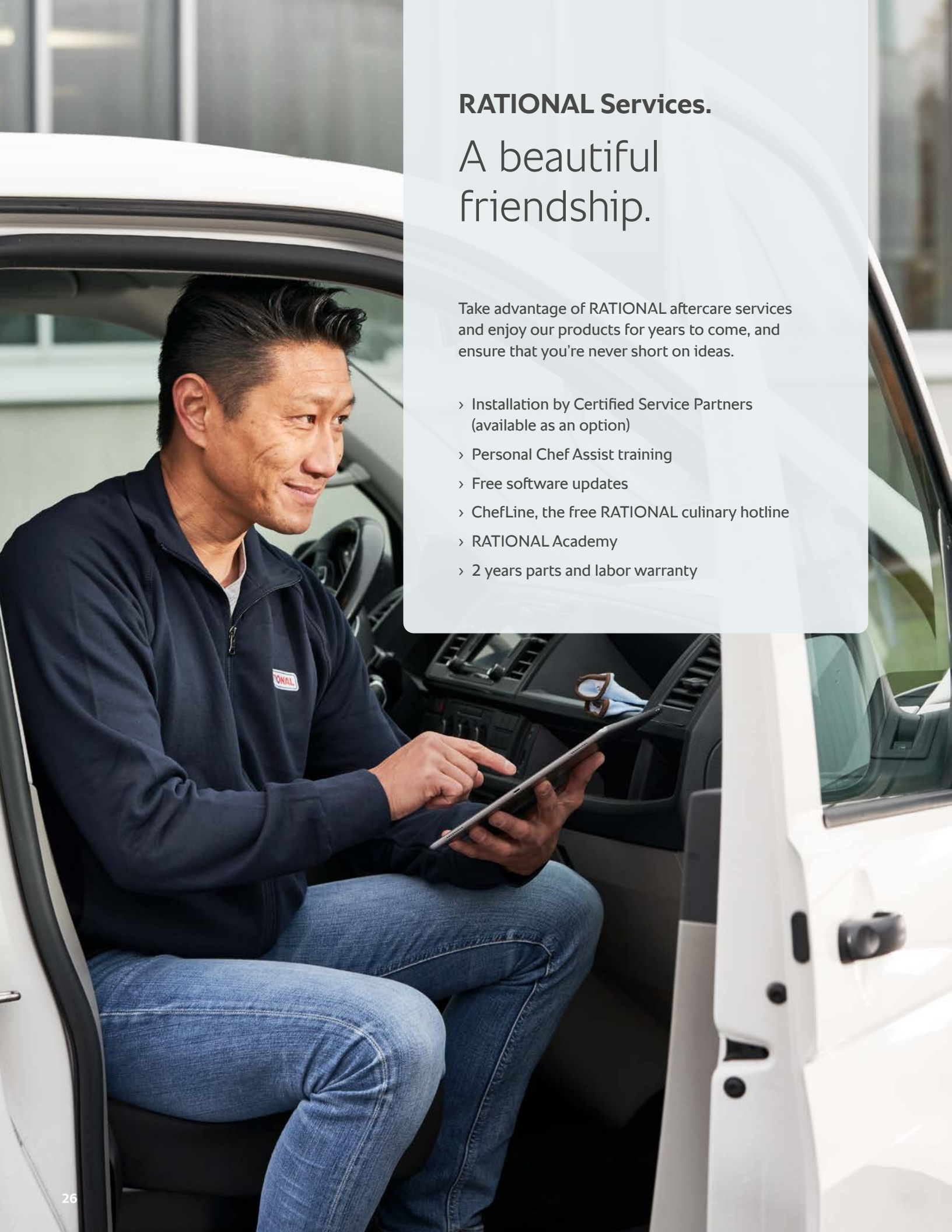

## RATIONAL Services.

# A beautiful friendship.

Take advantage of RATIONAL aftercare services and enjoy our products for years to come, and ensure that you're never short on ideas.

- › Installation by Certified Service Partners (available as an option)
- › Personal Chef Assist training
- › Free software updates
- › ChefLine, the free RATIONAL culinary hotline
- › RATIONAL Academy
- › 2 years parts and labor warranty

## The bottom line.

# Let's crunch the numbers together.

What makes a kitchen successful? When the investments pay off. Success with the iVario:

- › Usable immediately
- › Replaces numerous kitchen appliances
- › Makes additional investments unnecessary
- › Saves time, space, labor, ingredients, electricity, and water
- › Extremely short ROI time

Return on Investment period  
under one year

Your profit	Calculation method per year	Your additional earnings per year	Calculate for yourself
<b>Meat</b>			
Reduce your raw ingredient quantities by up to 10% (stews, casseroles) thanks to iVarioBoost's cooking power. Overnight cooking reduces raw materials usage on braised dishes by up to 10%*.	Ingredients used with conventional ranges, tilting skillets and kettles \$111,320	= \$11,130	
	Ingredients used with iVario \$100,190		
<b>Energy</b>			
Average savings of 68 kWh per service thanks to ultra-efficient iVarioBoost heating system*.	68 kWh × 2 shifts × 5 days × 50 weeks × \$0.23 per kWh	= \$7,820	
<b>Working time</b>			
Automatic cooking with iCookingSuite, overnight cooking, and speed of iVarioBoost heating saves an average of 120 minutes of work time per day, per unit.	1,000 hours × \$19 (hourly rate averaged between cooks/cleaning crew)	= \$18,500	
<b>Cleaning</b>			
Average annual savings of water and dishwashing liquid.* No more soaking tilting pans or boilers.	159 gallons of water per shift × \$7/1,000 gallons and 13.2 gallons of dishwashing liquid	= \$660	
<b>Your additional earnings per year</b>		<b>= \$38,110</b>	

Average restaurant serving 600 meals per day (2 shifts) using one iVario Pro L and XL, additional earnings compared to operating with a conventional stove, tilt skillet, boiler, and deep-fat fryer.

\* Compared to conventional tilting skillets, kettles, and deep-fryers.

## Our standard.

# Sustainable product quality.

Robust, solid, ready for everyday use – those are our expectations on every cooking system. That pays off not only in terms of product quality, but also in sustainability:

- › Longer life cycle thanks to meticulous production
- › High standard of quality, built to be serviced and maintained
- › Large proportion of recyclable materials
- › Ergonomic work
- › Intuitive training and work

# iVario model overview.

## Which one is right for you?



- 1 iVario with base and feet
- 2 Curb installation
- 3 iVario with casters
- 4 iVario integrated into kitchen block



iVario	2-XS	Pro 2-S	Pro L	Pro XL
Number of meals	30 and up	50 - 100	100 - 300	100 - 500
Usable capacity	2 x 4.5 gal 2 x 17 litre	2 x 6.5 gal 2 x 25 litre	26 gal 100 litre	40 gal 150 litre
Cooking surface area	2 x 2/3 GN (2 x 195 5/8 in <sup>2</sup> ) (2 x 13 dm <sup>2</sup> )	2 x 1/1 GN (2 x 292 1/4 in <sup>2</sup> ) (2 x 19 dm <sup>2</sup> )	2/1 GN (611 3/8 in <sup>2</sup> ) (39 dm <sup>2</sup> )	3/1 GN (906 1/2 in <sup>2</sup> ) (59 dm <sup>2</sup> )
Width	43 1/4" (1100 mm)	43 1/4" (1100 mm)	40 1/2" (1030 mm)	53 3/4" (1365 mm)
Depth	29 3/4" (756 mm)	36 7/8" (938 mm)	35 1/4" (894 mm)	35 1/4" (894 mm)
Height (incl. stand/base)	19 1/8" (42 1/2") 485 mm (1080 mm)	19 1/8" (42 1/2") 485 mm (1080 mm)	23 7/8" (42 1/2") 608 mm (1078 mm)	23 7/8" (42 1/2") 608 mm (1078 mm)
Weight	258 lb (117 kg)	295 lb (134 kg)	432 lb (196 kg)	520 lb (236 kg)
Water inlet	NPS 3/4"	NPS 3/4"	NPS 3/4"	NPS 3/4"
Water drain	1 1/2" OD 40 mm	1 1/2" OD 40 mm	2" OD 50 mm	2" OD 50 mm
Connected load (3 ph 208 V/3 ph 240 V)	15 kW/15 kW	23 kW/22 kW	23 kW/22 kW	34 kW/37 kW
Fuse (3 ph 208 V/3 ph 240 V)	60 A/45 A	70 A/70 A	70 A/70 A	125 A/125 A
Connected load (3 ph 440 V/3 ph 480 V)	13 kW/15 kW	19 kW/22 kW	25 kW/29 kW	38 kW/44kW
Fuse (3 ph 440 V/3 ph 480 V)	25 A / 25 A	35 A/ 35 A	45 A / 45 A	70 A / 70 A
<b>Options</b>				
Pressure cooking	–	○	○	○
iZoneControl	○	●	●	●
Low-temperature cooking (overnight, sous vide, confit)	○	●	●	●
WiFi	○	●	●	●

### Performance examples (per pan)

	10 lb	15 lb	33 lb	53 lb
<b>Searing meat for stew</b>				
Cooking time	5 min.	5 min.	5 min.	5 min.
<b>Cook stew (meat and sauce)</b>				
Cooking time without pressure	188 min.	188 min.	188 min.	188 min.
Cooking time with pressure	–	102 min. <span style="color: blue;">↓ -46%</span>	102 min. <span style="color: blue;">↓ -46%</span>	102 min. <span style="color: blue;">↓ -46%</span>
<b>Chickpeas, soaked</b>				
Cooking time without pressure	65 min.	65 min.	65 min.	65 min.
Cooking time with pressure	–	42 min. <span style="color: blue;">↓ -35%</span>	42 min. <span style="color: blue;">↓ -35%</span>	42 min. <span style="color: blue;">↓ -35%</span>
<b>Red potatoes</b>				
Cooking time without pressure	43 min.	43 min.	43 min.	43 min.
Cooking time with pressure	–	34 min. <span style="color: blue;">↓ -21%</span>	34 min. <span style="color: blue;">↓ -21%</span>	34 min. <span style="color: blue;">↓ -21%</span>

● Standard ○ Optional – Not available



Attention CA Residents:  
Prop 65 Warning. This warning applies to all units in this brochure.

**iVario live.**

# Cook with our experts.

Nothing's more convincing than first-hand knowledge. Experience RATIONAL cooking systems up close, see their features in action, and learn how to work with them. Live and with no obligation – right in your area.



**Register now**  
[info@rational-online.us](mailto:info@rational-online.us)

**RATIONAL USA**

1701 Golf Road  
Suite C-120, Commerce  
Rolling Meadows, IL 60008

Tel. 888-320-7274 (Toll Free)  
Fax 847-755-9583

[info@rational-online.us](mailto:info@rational-online.us)  
[rationalusa.com](http://rationalusa.com)

