



Sandwich Units

STANDARD TOPS, MIGHTY TOPS & CUTTING TOPS



Continental[®]
Refrigerator

INNOVATIVE DESIGNS FOR YOUR FOODSERVICE NEEDS

Sandwich Units

Standard, Mighty & Cutting Tops

Sandwich Units offer a unique air flow distribution (full length evaporator coil across back of unit) which allows pan product to maintain 33° – 41°F. Cabinet has a stainless steel front, top and end panels with aluminum back and interior. Units also feature insulated lids and a full-length nylon cutting board. Doors are field rehingeable. Pan top configurations can be modified to meet the needs of the operator. Front breathing and drawer options available.

Performance & Reliability

Performance-run tested for a minimum of 12 hours providing a highly sophisticated temperature analysis recording, exclusive to each cabinet.



FLEXIBILITY

Modifications Made Easy.

At Continental Refrigerator, we know the foodservice industry is an ever-changing environment. We are reminded of this every day through feedback from our customers, both directly and through our network of representatives. In fact, customer feedback has often lead to our custom engineering modifications becoming standard product features.

For this reason, we pride ourselves in delivering feature-rich refrigeration equipment solutions designed specifically for the commercial foodservice market. Whether it's kitchen ambient, food safety, limited space or storage challenges, our products are packed with flexible options that provide **real** operator benefits out of the box. This flexibility, a key differentiator of our products, enables our customers to modify base product features strategic to the way they operate their kitchen or bar environment.

Shown: SW60N24M



Consult factory for other modifications

www.continentalrefrigerator.com

Sandwich Units offer a host of options that can help you modify these prep tables to your operation. Choose from either **Standard Top** or **Cutting Top** models which accommodate two rows of 1/6-size recessed pans or **Mighty Top** models that provide for a third row of 1/6-size recessed pans. Popular options include:

Front Breathing

A unique, field assembled, bottom-mounted ventilation system designed to allow cabinets to be flush against a wall or built into a counter to conserve space (intake/exhaust from the front)

2-Tier Drawers

With easy in-the-field conversion from "door to drawer" or "drawer to door"

Cutting Board Material

Nylon is standard, composite is an option

Lid Options

Standard insulated hood and lid, optional insulated flat lid, hinged glass lid with integral stainless steel gas spring lid supports or optional vision panel lids as either a hood & lid w/ vision panel or flat lid w/ vision panel

Overshelves

16-gauge stainless steel, single or double for added storage

Pan Configurations

Modify pan openings to the needs of your product flow



Call us toll free at (800) 523-7138

Overview of Models & Standard Features

Door Configurations by Widths (shown with casters)

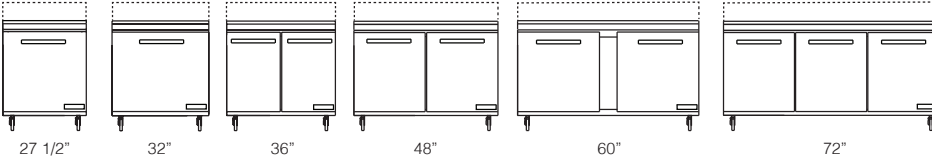

Two-Tier Drawer Configurations by Widths (two-tier drawers are standard on -D models)

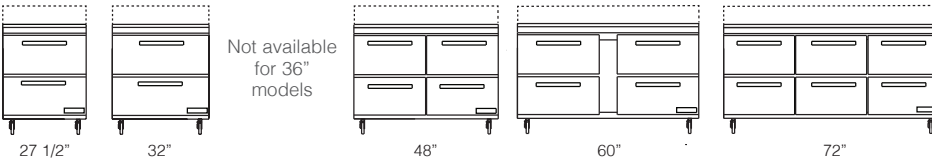

Note: Front breathing models (not shown), have the same door/drawer configuration.

Side View (Door and drawer models are the same depth. Dimensions shown below include bumpers, handles and cutting board)

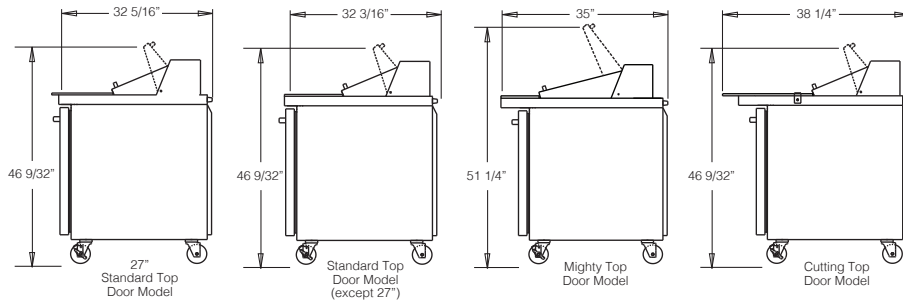

Drawer Pan Configurations

MODELS	TWO TIER DRAWERS
SW27N/SW60N	(1) 12 x 20 x 6 pan per drawer
SW32N	(1) 12 x 20 x 6 pan per drawer or (1) 1/2 size x 6 & (2) 1/3 size x 6 pans per drawer
SW48N/SW72N	(1) 1/2 size x 6 & (1) 1/3 size x 6 pan per drawer

Standard Features

Stainless steel front, top and end panels, aluminum back and interior

Performance-rated refrigeration system

Environmentally-safe R-290 refrigerant

2" non-CFC polyurethane foam insulation

Smoothed, polished chrome door/drawer handles

Automatic, hot gas condensate evaporator

Spring loaded, self closing doors

Magnetic, snap-in Santoprene™ door gaskets

Heavy duty, epoxy-coated steel shelves

Automatic, energy-saving, non-electric condensate evaporator

Non-corrosive, plasticized fin evaporator coil

Easily serviceable, back-mounted compressor

Full length nylon cutting board
- 12" deep - Standard Tops
- 8" deep - Mighty Tops
- 19" deep - Cutting Tops

Electronic controller w/ digital display & hi-low alarm

Expansion valve system (48" - 72" models only)

Completely enclosed, vented and removable case back

1/6 size recessed pans, 4" deep (can hold up to 6")

Insulated lids

Casters
- 5" high - Standard models
- 3 3/4" high - Front Breathing models

Field rehingeable doors (consult factory for hinges)

Pan Top Configurations

Standard Tops

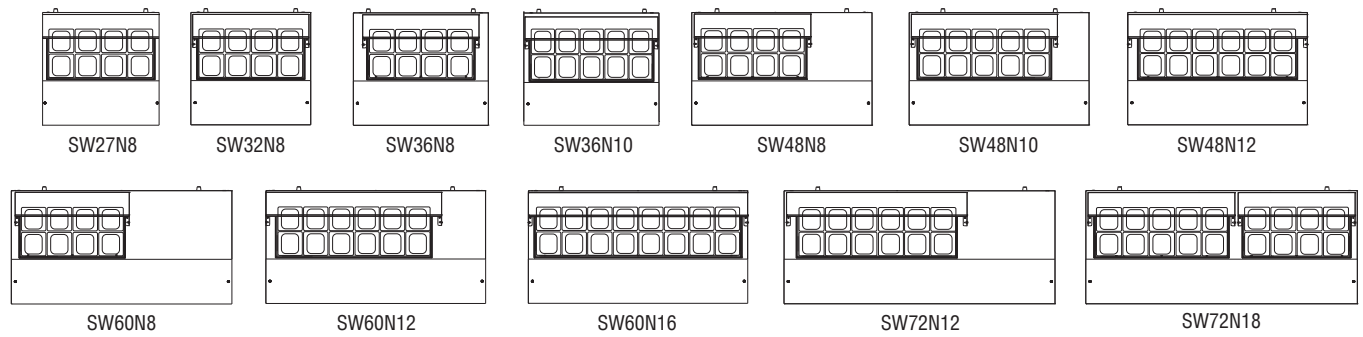

Mighty Tops

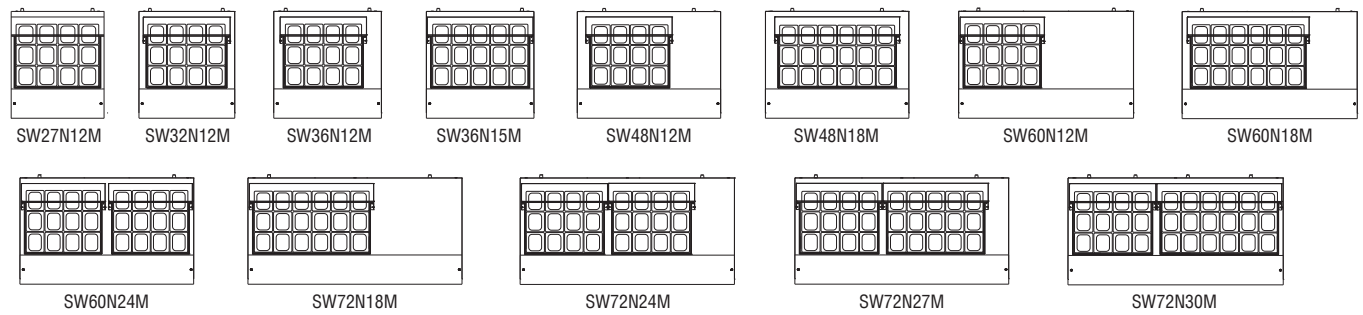

Cutting Tops

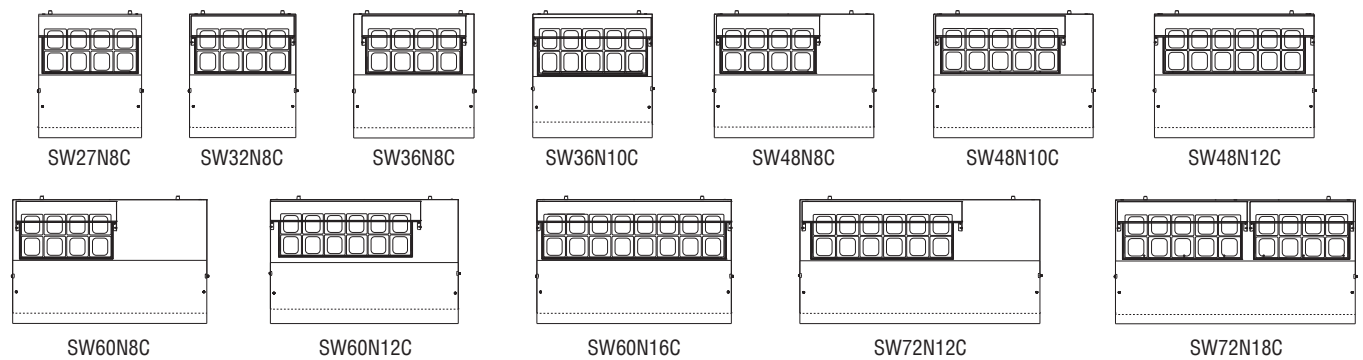

Specifications

Standard Top Models

SIZE	WITH DOOR(S)	WITH DRAWERS	EXTERIOR DIMENSIONS INCHES W x D x H	CAPACITY BTU/HR*	H.P.	SHIP WEIGHT
27"	SW27N8	SW27N8-D	27 1/2 x 32 3/16 x 42 1/4	1625	1/5	180
32"	SW32N8	SW32N8-D	32 x 32 3/16 x 42 1/4	1625	1/5	236
36"	SW36N8	not available	36 x 32 3/16 x 42 1/4	1625	1/5	254
	SW36N10	not available	36 x 32 3/16 x 42 1/4	1625	1/5	254
48"	SW48N8	SW48N8-D	48 x 32 3/16 x 42 1/4	1940	1/4+	267
	SW48N10	SW48N10-D	48 x 32 3/16 x 42 1/4	1940	1/4+	268
	SW48N12	SW48N12-D	48 x 32 3/16 x 42 1/4	1940	1/4+	270
60"	SW60N8	SW60N8-D	60 x 32 3/16 x 42 1/4	2560	1/3+	309
	SW60N12	SW60N12-D	60 x 32 3/16 x 42 1/4	2560	1/3+	311
	SW60N16	SW60N16-D	60 x 32 3/16 x 42 1/4	2560	1/3+	315
72"	SW72N12	SW72N12-D	72 x 32 3/16 x 42 1/4	2560	1/3+	385
	SW72N18	SW72N18-D	72 x 32 3/16 x 42 1/4	2560	1/3+	389

Mighty Top Models

27"	SW27N12M	SW27N12M-D	27 1/2 x 35 x 42 1/4	1625	1/5	188
32"	SW32N12M	SW32N12M-D	32 x 35 x 42 1/4	1625	1/5	236
36"	SW36N12M	not available	36 x 35 x 42 1/4	1625	1/5	254
	SW36N12M-HGL	not available	36 x 35 x 36 13/16	1625	1/5	272
	SW36N15M	not available	36 x 35 x 42 1/4	1625	1/5	254
48"	SW48N12M	SW48N12M-D	48 x 35 x 42 1/4	1940	1/4+	282
	SW48N18M	SW48N18M-D	48 x 35 x 42 1/4	1940	1/4+	285
	SW48N18M-HGL	SW48N18M-HGL-D	48 x 35 x 36 13/16	1940	1/4+	313
60"	SW60N12M	SW60N12M-D	60 x 35 x 42 1/4	2560	1/3+	319
	SW60N18M	SW60N18M-D	60 x 35 x 42 1/4	2560	1/3+	322
	SW60N24M	SW60N24M-D	60 x 35 x 42 1/4	2560	1/3+	330
	SW60N24M-HGL	SW60N24M-HGL-D	60 x 35 x 36 13/16	2560	1/3+	368
72"	SW72N18M	SW72N18M-D	72 x 35 x 42 1/4	2560	1/3+	398
	SW72N24M	SW72N24M-D	72 X 35X 42 1/4	2560	1/3+	408
	SW72N27M	SW72N27M-D	72 x 35 x 42 1/4	2560	1/3+	414
	SW72N30M	SW72N30M-D	72 x 35 x 42 1/4	2560	1/3+	420
	SW72N30M-HGL	SW72N30M-HGL-D	72 x 35 x 36 13/16	2560	1/3+	468

Cutting Top Models

27"	SW27N8C	SW27N8C-D	27 1/2 x 38 1/4 x 42 1/4	1625	1/5	180
32"	SW32N8C	SW32N8C-D	32 x 38 1/4 x 42 1/4	1625	1/5	236
36"	SW36N8C	not available	36 x 38 1/4 x 42 1/4	1625	1/5	254
	SW36N10C	not available	36 x 38 1/4 x 42 1/4	1625	1/5	254
48"	SW48N-8C	SW48N8C-D	48 x 38 1/4 x 42 1/4	1940	1/4+	267
	SW48N10C	SW48N10C-D	48 x 38 1/4 x 42 1/4	1940	1/4+	268
	SW48N12C	SW48N12C-D	48 x 38 1/4 x 42 1/4	1940	1/4+	270
60"	SW60N8C	SW60N8C-D	60 x 38 1/4 x 42 1/4	2560	1/3+	309
	SW60N12C	SW60N12C-D	60 x 38 1/4 x 42 1/4	2560	1/3+	311
	SW60N16C	SW60N16C-D	60 x 38 1/4 x 42 1/4	2560	1/3+	315
72"	SW72N12C	SW72N12C-D	72 x 38 1/4 x 42 1/4	2560	1/3+	385
	SW72N18C	SW72N18C-D	72 x 38 1/4 x 42 1/4	2560	1/3+	389

*BTU/HR Rating @ +25°F, 90°F ambient.
10 ft. cord and plug attached (115-60-1 volts)

Note: Hinged Glass Lid (HGL) available only for model sizes listed in bold

Specifications - Front Breathing

Standard Top Models - Front Breathing

SIZE	WITH DOOR(S)	WITH DRAWERS	EXTERIOR DIMENSIONS INCHES W x D x H	CAPACITY BTU/HR*	H.P.	SHIP WEIGHT
27"	SW27N8-FB	SW27N8-FB-D	27 1/2 x 32 3/16 x 41	1625	1/5	180
32"	SW32N8-FB	SW32N8-FB-D	32 x 32 3/16 x 41	1625	1/5	236
36"	SW36N8-FB	not available	36 x 32 3/16 x 41	1625	1/5	254
	SW36N10-FB	not available	36 x 32 3/16 x 41	1625	1/5	254
48"	SW48N8-FB	SW48N8-FB-D	48 x 32 3/16 x 41	1940	1/4+	267
	SW48N10-FB	SW48N10-FB-D	48 x 32 3/16 x 41	1940	1/4+	268
	SW48N12-FB	SW48N12-FB-D	48 x 32 3/16 x 41	1940	1/4+	270
60"	SW60N8-FB	SW60N8-FB-D	60 x 32 3/16 x 41	2560	1/3+	309
	SW60N12-FB	SW60N12-FB-D	60 x 32 3/16 x 41	2560	1/3+	311
	SW60N16-FB	SW60N16-FB-D	60 x 32 3/16 x 41	2560	1/3+	315
72"	SW72N12-FB	SW72N12-FB-D	72 x 32 3/16 x 41	2560	1/3+	385
	SW72N18-FB	SW72N18-FB-D	72 x 32 3/16 x 41	2560	1/3+	389

Mighty Top Models - Front Breathing

27"	SW27N12M-FB	SW27N12M-FB-D	27 1/2 x 35 x 41	1625	1/5	188
32"	SW32N12M-FB	SW32N12M-FB-D	32 x 35 x 41	1625	1/5	236
36"	SW36N12M-FB	not available	36 x 35 x 41	1625	1/5	254
	SW36N12M-HGL-FB	not available	36 x 35 x 35 9/16	1625	1/5	272
	SW36N15M-FB	not available	36 x 35 x 41	1625	1/5	254
48"	SW48N12M-FB	SW48N12M-FB-D	48 x 35 x 41	1940	1/4+	282
	SW48N18M-FB	SW48N18M-FB-D	48 x 35 x 41	1940	1/4+	285
	SW48N18M-HGL-FB	SW48N18M-HGL-FB-D	48 x 35 x 35 9/16	1940	1/4+	313
60"	SW60N12M-FB	SW60N12M-FB-D	60 x 35 x 41	2560	1/3+	319
	SW60N18M-FB	SW60N18M-FB-D	60 x 35 x 41	2560	1/3+	322
	SW60N24M-FB	SW60N24M-FB-D	60 x 35 x 41	2560	1/3+	330
	SW60N24M-HGL-FB	SW60N24M-HGL-FB-D	60 x 35 x 35 9/16	2560	1/3+	368
72"	SW72N18M-FB	SW72N18M-FB-D	72 x 35 x 41	2560	1/3+	398
	SW72N27M-FB	SW72N27M-FB-D	72 x 35 x 41	2560	1/3+	414
	SW72N24M-FB	SW72N24M-FB-D	72 X 35X 42 1/4	2560	1/3+	408
	SW72N30M-FB	SW72N30M-FB-D	72 x 35 x 41	2560	1/3+	420
	SW72N30M-HGL-FB	SW72N30M-HGL-FB-D	72 x 35 x 35 9/16	2560	1/3+	468

Cutting Top Models - Front Breathing

27"	SW27N8C-FB	SW27N8C-FB-D	27 1/2 x 38 1/4 x 41	1625	1/5	180
32"	SW32N8C-FB	SW32N8C-FB-D	32 x 38 1/4 x 41	1625	1/5	236
36"	SW36N8C-FB	not available	36 x 38 1/4 x 41	1625	1/5	254
	SW36N10C-FB	not available	36 x 38 1/4 x 41	1625	1/5	254
48"	SW48N8C-FB	SW48N8C-FB-D	48 x 38 1/4 x 41	1940	1/4+	267
	SW48N10C-FB	SW48N10C-FB-D	48 x 38 1/4 x 41	1940	1/4+	268
	SW48N12C-FB	SW48N12C-FB-D	48 x 38 1/4 x 41	1940	1/4+	270
60"	SW60N8C-FB	SW60N8C-FB-D	60 x 38 1/4 x 41	2560	1/3+	309
	SW60N12C-FB	SW60N12C-FB-D	60 x 38 1/4 x 41	2560	1/3+	311
	SW60N16C-FB	SW60N16C-FB-D	60 x 38 1/4 x 41	2560	1/3+	315
72"	SW72N12C-FB	SW72N12C-FB-D	72 x 38 1/4 x 41	2560	1/3+	385
	SW72N18C-FB	SW72N18C-FB-D	72 x 38 1/4 x 41	2560	1/3+	389

*BTU/HR Rating @ +25°F, 90°F ambient.
10 ft. cord and plug attached (115-60-1 volts)

Note: Hinged Glass Lid (HGL) available only for model sizes listed in bold

Call us toll free at (800) 523-7138

- Door/drawer locks
- Overshelves (not available on HGL models)
- Adjustable legs
- Rear-mounted cutting board
- Crumb catcher (not available on -C Cutting Top models)
- 1/9 size crumb pans recessed into cutting board
- Add'l epoxy-coated, steel shelves
- Stainless steel shelves
- Stainless steel interior
- Flat insulated night cover (flat lid)
- Vision panel lid
- Stainless steel back
- Optional caster sizes
- Composite cutting board
- Modified pan openings
- Top extensions



Adjustable legs



Vision panel lid



1/9 size crumb pan recessed into cutting board

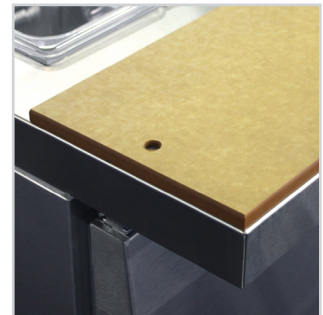

Composite cutting board

Engineering, Manufacturing & Quality Control

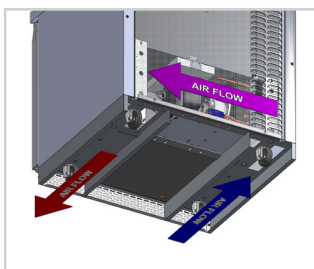

Front breathing air flow

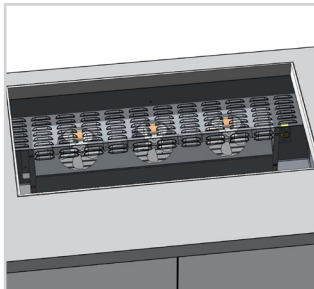

View of fans on a SW48 model

Continental Refrigerator engineers and builds our Sandwich Units to meet the most stringent specifications demanded by consultants and service operators. All cabinets are constructed of top quality materials and components, attributing to their genuine ruggedness and durability. Our Sandwich Units are designed with enhancements to endure everyday use in harsh commercial kitchen environments.

Prior to factory shipping, all models are performance-run tested for a minimum of 12 hours, providing a highly sophisticated temperature analysis recording, exclusive to each individual cabinet. This recording is then supplied, along with the unit's operation manual, for the customer. A final leak test, vibration check, noise level and visual examination is made by our quality control team, to assure a superior product is shipped from our factory.

Air Flow

Unique air flow distribution allows pan product to maintain 33° - 41°F.

Number of Fans

SW27N	2
SW32N	2
SW36N	2
SW48N	3
SW60N	3
SW72N	4

Front Breathing

Front breathing option is a unique field-assembled, bottom-mounted ventilation system designed to allow cabinets to be flush against a wall or built into a counter to conserve space.

Product design and specifications are subject to change without prior notice.

How to Buy

LOCAL SALES REPRESENTATIVES			STATES COVERED
Wyllie Marketing	Weymouth, MA	(781) 340-6157	ME, RI, NH, MA, VT, CT
Link 2 Hospitality Solutions	Rochester, NY	(585) 254-1780	Upstate NY
C.R. Peterson Associates	Avon, MA	(800) 257-4040	N. NJ, New York City
Schmid Dewland & Associates	Marlton, NJ	(856) 783-3400	E. PA, DE, S. & Central NJ
Link 2 Hospitality Solutions	Bridgeville, PA	(412) 341-2020	W. PA, W. VA (except Panhandle)
High Sabatino Associates, Inc.	Jessup, MD	(301) 470-7051	DC, MD, VA, W. VA (Panhandle)
Stiefel Associates, Inc.	Lansing, MI	(517) 393-3019	MI (except Upper Peninsula)
Alliance Foodservice Equipment	Pickerington, OH	(800) 833-0797	OH, KY
Stiefel Associates, Inc.	Edinburgh, IN	(800) 832-6442	IN
Jay Mark Group, LTD	Elk Grove Village, IL	(847) 545-1918	N. IL
North Star Agency	Minneapolis, MN	(763) 545-1400	MN, ND, SD
Mirkovich & Associates	Waukesha, WI	(630) 792-0080	WI, MI (Upper Peninsula)
Select Marketing	St. Louis, MO	(314) 961-3332	MO, KS, IA, NE, S. IL
Premier Foodservice Group	Norcross, GA	(877) 667-2192	NC, SC
Pro-Quip Foodservice	Little Rock, AR	(501) 221-7120	AR, LA, MS, W. TN (W. of Tenn. River)
The Veitch Group	Ft. Lauderdale, FL	(954) 316-6162	FL (except Panhandle)
Merkolat	Pembroke Pines, FL	(864) 248-6260	Latin America, Caribbean
Premier Foodservice Group	Norcross, GA	(877) 667-2192	AI, FL (Panhandle), GA, E. TN (E. of Tenn River)
Desert Peak Marketing	Denver, CO	(303) 790-2424	CO, S. ID, MT, UT WY
Roller & Associates	Seattle, WA	(206) 547-3555	WA, OR, AK, N. ID
Foodservice Equipment Agents	Placentia, CA	(714) 693-3329	AZ (Bull Head City), S. CA, S. NV
Inform Foodservice Solutions	Walnut Creek, CA	(800) 655-7756	N. CA, N. NV
EMC Hospitality	Kealahou, HI	(808) 315-2077	HI
Desert Peak Marketing	Phoenix, AZ	(602) 255-0976	AZ (except Bull Head City), NM, TX (El Paso)
Forbes Hever & Wallace, Inc.	Coppell, TX	(972) 219-8898	OK, TX (except El Paso)



A Division of National Refrigeration & Air Conditioning Products

Continental Refrigerator | Local: (215) 244-1400
539 Dunksferry Road | Toll Free: (800) 523-7138
Bensalem, PA 19020 | Fax: (215) 244-9579

www.continentalrefrigerator.com

Continental[®]

Refrigerator

INNOVATIVE DESIGNS FOR YOUR FOODSERVICE NEEDS



PROUDLY
DESIGNED & ASSEMBLED
IN THE U.S.A.