



Milk Coolers

COLD WALL & FORCED AIR



Continental[®]
Refrigerator

INNOVATIVE DESIGNS FOR YOUR FOODSERVICE NEEDS

Milk Coolers

Refrigerator & Freezer

Cold wall or forced air performance-rated refrigerated milk coolers, either single or dual access, are designed to keep milk products cold prior to serving. Cabinet construction consists of stainless steel top, lid, and door, white finish or stainless steel body and galvanized steel interior (stainless steel interior on -SS models). Reinforced stainless steel floor provides added durability.

Design & Safety

Custom laminates are available to allow your unit to reflect your company branding or an artistic atmosphere. Corner or wrap-around bumpers provide safety in youth-oriented environments.

Performance & Reliability

Performance-run tested for a minimum of 12 hours providing a highly sophisticated temperature analysis recording, exclusive to each cabinet.



FLEXIBILITY

Modifications Made Easy.

At Continental Refrigerator, we know the foodservice industry is an ever-changing environment. We are reminded of this every day through feedback from our customers, both directly and through our network of representatives. In fact, customer feedback has often lead to our custom engineering modifications becoming standard product features.

For this reason, we pride ourselves in delivering feature-rich refrigeration equipment solutions designed specifically for the commercial foodservice market. Whether it's kitchen ambient, food safety, limited space or storage challenges, our products are packed with flexible options that provide **real** operator benefits out of the box. This flexibility, a key differentiator of our products, enables our customers to modify base product features strategic to the way they operate their kitchen or bar environment.

Shown: MC4NSCW

Standard Model (Cold Wall)



Stainless Steel Exterior



Custom Laminates



Dual Access



Corner Bumpers
(see next page)



Wrap Around Bumpers
& Foot Lock (see next page)

Consult factory for other modifications

Standard Features & Specifications

Standard Features

Performance-rated refrigeration system

Designed to keep milk cold during serving

Unique forced air flow curtain (Forced Air models)

Environmentally-safe R-290 refrigerant

2" high density, non-CFC polyurethane foamed-in-place insulation

Heavy-duty stainless steel lid, door hinges and latches

Built-in, electric condensate evaporator (Forced Air models)

Easily serviceable, bottom-mounted condensing unit

Electronic controller w/ digital display & hi-low alarm

Snap-in lid and door gaskets

Non-corrosive, heavy-duty, epoxy-coated steel wire floor racks

Cylinder-keyed security lock

5" swivel casters w/ front locking brakes (factory installed)

Reinforced stainless steel floor for added durability

Floor drain

Specifications

Cold Wall Milk Cooler Models (White Painted Steel)

SIZE	SINGLE ACCESS MODELS	DUAL ACCESS MODELS	EXTERIOR DIMENSIONS W x D x H (INCH)	CRATE CAPACITY 13 x 13 x 11	CRATE CAPACITY 19 x 13 x 11	CAP. BTU/HR*	H.P.	SHIP WEIGHT
34"	MC3NSCW	MC3NDCW	34 x 33 x 41 1/2	8	4	1280	1/4+	335
48"	MC4NSCW	MC4NDCW	49 x 33 x 41 1/2	12	8	1725	1/3+	470
58"	MC5NSCW	MC5NDCW	58 x 33 x 41 1/2	16	10	1930	1/3+	580

Cold Wall Milk Cooler Models (Stainless Steel Exterior & Interior)

SIZE	SINGLE ACCESS MODELS	DUAL ACCESS MODELS	EXTERIOR DIMENSIONS W x D x H (INCH)	CRATE CAPACITY 13 x 13 x 11	CRATE CAPACITY 19 x 13 x 11	CAP. BTU/HR*	H.P.	SHIP WEIGHT
34"	MC3NSSCW	MC3NSSDCW	34 x 33 x 41 1/2	8	4	1280	1/4+	345
48"	MC4NSSCW	MC4SSDCW	49 x 33 x 41 1/2	12	8	1725	1/3+	485
58"	MC5NSSCW	MC5NSSDCW	58 x 33 x 41 1/2	16	10	1930	1/3+	595

Forced Air Milk Cooler Models (White Painted Steel)

SIZE	SINGLE ACCESS MODELS	DUAL ACCESS MODELS	EXTERIOR DIMENSIONS W x D x H (INCH)	CRATE CAPACITY 13 x 13 x 11	CRATE CAPACITY 19 x 13 x 11	CAP. BTU/HR*	H.P.	SHIP WEIGHT
34"	MC3NS	MC3ND	34 x 33 x 47	8	4	2080	1/4+	335
48"	MC4NS	MC4ND	49 x 33 x 47	12	8	2620	1/3+	470
58"	MC5NS	MC5ND	58 x 33 x 47	16	10	2870	1/3+	580

Forced Air Milk Cooler Models (Stainless Steel Exterior & Interior)

SIZE	SINGLE ACCESS MODELS	DUAL ACCESS MODELS	EXTERIOR DIMENSIONS W x D x H (INCH)	CRATE CAPACITY 13 x 13 x 11	CRATE CAPACITY 19 x 13 x 11	CAP. BTU/HR*	H.P.	SHIP WEIGHT
34"	MC3NSS	MC3NSSD	34 x 33 x 47	8	4	2080	1/4+	345
48"	MC4NSS	MC4NSSD	49 x 33 x 47	12	8	2620	1/3+	447
58"	MC5NSS	MC5NSSD	58 x 33 x 47	16	10	2870	1/3+	595

BTU/HR Rating @ +10°F, 90°F ambient (Cold Wall)
 BTU/HR Rating @ +25°F, 90°F ambient (Forced Air)
 Extra long, 10 ft. cord and plug attached (115-60-1 volts)

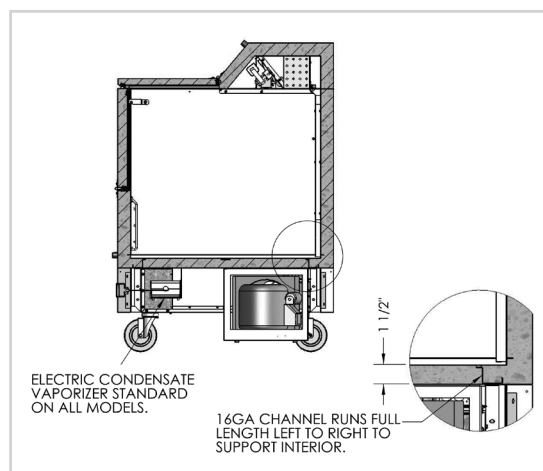

Electric condensate evaporator & Reinforced stainless steel floor

- Wrap around bumpers
- Floor foot pedal lock
- Corner bumpers
- Stainless steel interior
- Custom laminates
- Powder coating
- Adjustable legs



Corner bumper



Custom laminates



Floor foot pedal lock



Adjustable legs

Engineering, Manufacturing & Quality Control

Continental Refrigerator engineers and builds our Milk Coolers to meet the most stringent specifications demanded by consultants and service operators. All cabinets are constructed of top quality materials and components, attributing to their genuine ruggedness and durability. Our Milk Coolers are designed with enhancements to endure everyday use in typical commercial kitchen environments.

Prior to factory shipping, all models are performance-run tested for a minimum of 12 hours, providing a highly sophisticated temperature analysis recording, exclusive to each individual cabinet. This recording is then supplied, along with the unit's operation manual, for the customer. A final leak test, vibration check, noise level and visual examination is made by our quality control team, to assure a superior product is shipped from our factory.

Cold Wall & Forced Air

Cold Wall and forced air technology allows optimal cooling, keeping milk products cold prior to serving.



Airflow on MC4NS model

Product design and specifications are subject to change without prior notice.

How to Buy

LOCAL SALES REPRESENTATIVES

STATES COVERED

Wyllie Marketing	Weymouth, MA	(781) 340-6157	ME, RI, NH, MA, VT, CT
Link 2 Hospitality Solutions	Rochester, NY	(585) 254-1780	Upstate NY
C.R. Peterson Associates	Avon, MA	(800) 257-4040	N. NJ, New York City
Schmid Dewland & Associates	Marlton, NJ	(856) 783-3400	E. PA, DE, S. & Central NJ
Link 2 Hospitality Solutions	Bridgeville, PA	(412) 341-2020	W. PA, W. VA (except Panhandle)
High Sabatino Associates, Inc.	Jessup, MD	(301) 470-7051	DC, MD, VA, W. VA (Panhandle)
Stiefel Associates, Inc.	Lansing, MI	(517) 393-3019	MI (except Upper Peninsula)
Alliance Foodservice Equipment	Pickerington, OH	(800) 833-0797	OH, KY
Stiefel Associates, Inc.	Edinburgh, IN	(800) 832-6442	IN
Jay Mark Group, LTD	Elk Grove Village, IL	(847) 545-1918	N. IL
North Star Agency	Minneapolis, MN	(763) 545-1400	MN, ND, SD
Mirkovich & Associates	Waukesha, WI	(630) 792-0080	WI, MI (Upper Peninsula)
Select Marketing	St. Louis, MO	(314) 961-3332	MO, KS, IA, NE, S. IL
Premier Foodservice Group	Norcross, GA	(877) 667-2192	NC, SC
Pro-Quip Foodservice	Little Rock, AR	(501) 221-7120	AR, LA, MS, W. TN (W. of Tenn. River)
The Veitch Group	Ft. Lauderdale, FL	(954) 316-6162	FL (except Panhandle)
Merkolat	Pembroke Pines, FL	(864) 248-6260	Latin America, Caribbean
Premier Foodservice Group	Norcross, GA	(877) 667-2192	AI, FL (Panhandle), GA, E. TN (E. of Tenn River)
Desert Peak Marketing	Denver, CO	(303) 790-2424	CO, S. ID, MT, UT WY
Roller & Associates	Seattle, WA	(206) 547-3555	WA, OR, AK, N. ID
Foodservice Equipment Agents	Placentia, CA	(714) 693-3329	AZ (Bull Head City), S. CA, S. NV
Inform Foodservice Solutions	Walnut Creek, CA	(800) 655-7756	N. CA, N. NV
EMC Hospitality	Kealahou, HI	(808) 315-2077	HI
Desert Peak Marketing	Phoenix, AZ	(602) 255-0976	AZ (except Bull Head City), NM, TX (El Paso)
Forbes Hever & Wallace, Inc.	Coppell, TX	(972) 219-8898	OK, TX (except El Paso)



A Division of National Refrigeration & Air Conditioning Products

Continental Refrigerator | Local: (215) 244-1400
539 Dunksferry Road | Toll Free: (800) 523-7138
Bensalem, PA 19020 | Fax: (215) 244-9579

www.continentalrefrigerator.com

Continental[®]

Refrigerator

INNOVATIVE DESIGNS FOR YOUR FOODSERVICE NEEDS



PROUDLY
DESIGNED & ASSEMBLED
IN THE U.S.A.